

JPET #180687

Title:

Role of Calcium-activated Potassium Channels in the
Genesis of 3,4-diaminopyridine-induced Periodic
Contractions in Isolated Canine Coronary Artery Smooth
Muscles

Authors

Yasumi Uchida, M.D., Yuko Maezawa, M.D., Yoshiro Maezawa,
M.D., Yasuto Uchida, MD., Fumitaka Nakamura, M.D.

Japan Foundation for Cardiovascular Research, Funabashi, Japan
(Y.U.);

Department of Cardiology, Jikei University School of Medicine,
Tokyo, Japan (Y.U.)

Department of Clinical Cell Biology, Chiba University, Chiba
(Yu.M., Yo.M.);

Department of Cardiology, Toho University Medical Center Ohmori
Hospital, Tokyo (Yasuto.U.);

Third Department of Internal Medicine, Teikyo University,
Ichihara, Japan (F.N.).

JPET #180687

Running Title:

K_{Ca} in Periodic Coronary Contractions

Corresponding Author:

Yasumi Uchida, MD
Japan Foundation for Cardiovascular Research,
2-30-17, Funabashi, Japan, 274-0063.
Tel: +81-47-462-2159
E-mail: uchiy@ta2.so-net.ne.jp

Recommended section: Cardiovascular.

Number of pages: 32.

Number of tables: 7.

Number of figures: 8.

Number of references: 53.

Word Count: 5570.(abstract 263; introduction 345; discussion 1562).

JPET #180687

Abbreviations

3,4-DAP: 3,4-diaminopyridine.

PCs: Periodic contractions.

TC: Tonic contractions.

TMP: Transmembrane potential.

K_V: Voltage-gated potassium channels.

K_{Ca}: Calcium-activated potassium channels.

K_{ATP}: Adenosine triphosphate-sensitive potassium channels.

Cav: Voltage-gated calcium channels.

IbTX: Iberiotoxine.

ChTX: charybdotoxine.

JPET #180687

Abstract

Background: We found that 3,4-diaminopyridine (3,4-DAP), a voltage-gated potassium channel (K_V) inhibitor, elicits pH-sensitive periodic contractions (PCs) of coronary smooth muscles. Underlying mechanism(s) of PCs however remained to be elucidated. **Purpose:** The present study was performed to examine the roles of ion channels in the genesis of PCs. **Methods:** To determine the electromechanical changes of smooth muscles, isolated coronary arterial rings from beagles were suspended in organ chambers filled with Krebs-Henseleit solution and 10^{-2} mol/L 3,4-DAP was added to elicit PCs. **Results:** 3,4-DAP caused periodic spike-and-plateau depolarization accompanied by contraction. PCs were not produced when the $CaCl_2$ concentration in the chamber was $\leq 0.3 \times 10^{-3}$ or $\geq 10^{-2}$ mol/L. PCs were eliminated by a $CaCl_2$ concentration $\geq 5 \times 10^{-3}$ mol/L or by lowering pH below 7.20 with HCl and recovered by the addition of iberiotoxin or charybdotoxin which inhibit large-conductance calcium-activated potassium channels (K_{Ca}), or by elevating pH above 7.35 with NaOH. PCs, as well as the spike-and-plateau depolarization were eliminated by nifedipine, which inhibits L-type voltage-gated calcium channels (Ca_V). **Conclusions:** Influx of $Ca(2+)$ through L-type Ca_V which was opened because of closing of K_{Ca} secondary to 3,4-DAP-induced closing of K_V resulted in contraction; the intracellular $Ca(2+)$ increased by this influx opened K_{Ca} , leading to closure of Ca_V and consequent cessation of $Ca(2+)$ influx, with resultant relaxation; and these processes were repeated spontaneously to cause PCs. $H(+)$ and $OH(-)$ were considered to act opener and closer of K_{Ca} , respectively.

JPET #180687

Introduction

Periodic anginal attacks associated with elevation of the ST segment on the electrocardiogram, which are related to coronary spasm, are common in patients with vasospastic angina (Maseri, et al. 1978; Murao, et al, 1975; Prinzmetal, et al, 1959). The cycle length of the ST elevation ranges from 5 to 30 min (Murao, et al. 1975), but the underlying mechanisms of coronary spasm and its periodic occurrence are not well known.

Coronary arteries are very sensitive to pH changes in this category of coronary artery disease; anginal attacks due to coronary spasm are evoked by elevation of blood pH by hyperventilation and Tris buffer infusion, and are suppressed by lowering blood pH by hypoventilation (Yasue, et al. 1978).

Coronary spasm can be provoked by intracoronary administration of ergonovine (Sirgel, 2010) or acetylcholine (Yasue, et a. 1978) in patients. In animals, coronary spasm can be provoked by histamine (Yamamoto Y, et al. 1987) or serotonin (Fukai T, et al. 1993; Mitsuoka, et al. 1995). However, none of them can provoke pH-sensitive periodic coronary spasm.

During a search for an experimental model for this type of periodic coronary spasm, we discovered that 3,4-diaminopyridine (3,4-DAP), which inhibits (closes) voltage-gated potassium channels (K_V)(Felt, et al, 2010; Kirsch and Narahashi, 1978; Robertoson and Nelson, 1994) and is used clinically to treat neuromuscular diseases (Felt, et al, 2010), causes spontaneous and periodic contractions (PCs) of isolated in-vitro animal and human coronary arteries which are sensitive to the changes in pH and continue for more than 12 hours with a cycle length similar to that of vasospastic anginal attacks (Uchida and Sugimoto, 1984). These PCs are associated with perinuclear vacuolization of the coronary smooth muscle cells, a typical morphological change observed with spasm (Joris and Majino, 1981; Uchida, 1985; Uchida, et al. 2011). However, the underlying mechanism (s) for periodic nature and pH-sensitive nature of PCs remained obscure.

The present in-vitro study aimed to clarify the periodic nature and

JPET #180687

pH-sensitive nature of the PCs of coronary smooth muscles.

Materials and Methods

1. Preparation of Coronary Arterial Rings.

We conducted the experiments at the Jikei University School of Medicine Institute for Animal Experiments and the protocol was approved by the University Administrative Panel on Laboratory Animal Care.

To prepare the coronary arterial rings, 41 male beagles (8-15 Kg) were anesthetized with sodium pentobarbital (30 mg/Kg, i.v.) and each beating heart was removed and immersed in cold Krebs-Henseleit solution (KHS) that contained (in mmol/L): NaCl 118, KCl 4.7, CaCl₂ 2.5, MgSO₄ 1.2, KH₂PO₄ 1.2, NaHCO₃ 2.5, and glucose 10.0.

The proximal segments 2 - 3 cm in length of the left anterior descending coronary artery and circumflex artery were carefully dissected free of the surrounding tissues using two pairs of microscopic dissection forceps and then removed from the myocardium by transecting both ends. The isolated arteries were cut into rings that were 2 mm long.

2. Recording of Mechanical Activity

Each coronary arterial ring was suspended by two tungsten hooks under a resting tension of 2 g in an organ chamber filled with 20 ml of KHS at 37°C and gassed with 95% O₂ and 5% CO₂. The pH of the solution was 7.40 - 7.45.

Ten to 14 rings obtained from a beagle were suspended in 10 to 14 chambers simultaneously and each ring was used for different examination. Two g resting tension was applied in order to prevent contraction-induced detachment of the electrode used for measurement of electrical activity and because force developed maximally at this resting tension in a preliminary study. Force was measured with an isometric force displacement transducer (T-7-30, Tokyo Baldwin, Tokyo, Japan) and recorded on an ink writing oscillograph (Type 8s, Sanei Instrument, Tokyo, Japan).

JPET #180687

3. Recording Both Transmembrane Potential (TMP) and Mechanical Activity

Each ring was suspended in an organ chamber (2 ml volume) and perfused with KHS at the rate of 5 ml/min. Force was recorded as described above.

Transmembrane potentials (TMP) were recorded with glass microelectrodes filled with 3 mol/L KCl and having a tip resistance of 30-80 M Ω . The microelectrodes were mounted on a hydraulic micro-manipulator (Narushige Scientific Inst. Lab., Tokyo, Japan) and were inserted from the outer surface of the rings. The criteria for successful penetration included: a sharp drop from baseline on entry of the electrode into a cell, and a sharp return to zero on withdrawal of the electrode (Harder, 1980).

4. Drug Administrations

After one hour equilibration period, the viability of each ring was tested by raising the potassium, i.e., K(+), concentration by 2.5×10^2 mol/L. At 15 min after repeated washing, 3,4-DAP (10^{-2} mol/L; Nakarai Chemical Co, Tokyo, Japan) was added to the chamber, and 3-30 min later, PCs developed in all rings.

When the cycle length and developed tension stabilized, drugs which might affect the cell membrane or intracellular contraction systems were dissolved in distilled water and was added to the chamber.

5. Evaluation of Drug Effects

The level of tension achieved after administration of 10^{-6} mol/L papaverine was called 0 g, and the tension of the contraction phase, duration of contraction at 20 % of tension development and the tension of the relaxation phase were compared with the average values of the three control cycles. The time to the reappearance of PCs after drug administrations was called the reappearance time; when it was significantly longer than the average value of the control three control cycle length, the PCs were considered to having been eliminated by the particular drug.

Similarly, the changes in TMP before and after administration of each drug were examined.

JPET #180687

6. Drugs

The drugs that were used in the present study were as follows:

- 1). Inhibitors of calcium-activated-potassium channels (K_{Ca})
Large-conductance K_{Ca} inhibitors: iberiotoxin (IbTX; Sigma-Aldrich Japan, Tokyo) (Latorre, et al, 1989; Marchenko and Sage, 1995); charybdotoxin (ChTX; Sigma-Aldrich Japan) (Miller, et al, 1985).
Small-conductance K_{Ca} inhibitor: apamine (Muraki, et al. 1997).
- 2). $CaCl_2$ (Wako, Osaka)
- 3). Inhibitors of L-type voltage-gated-calcium channels (Ca_V): nifedipine (Wako) (Medina, et al. 2010); verapamil (Wako) (Ko, et al. 2010),
- 4). Agonist of L-type Ca_V : Bay K 8644 (Sigma-Aldrich Japan) (Amobi, et al. 2010)
- 5) Acidic and alkaline substances: HCl, lactic acid, NaOH, $NaHCO_3$ (Wako).
- 6). Inhibitors of ion pumps:
Na-pump ($K(+)$ - $Na(+)$ - ATP ase) inhibitor: ouabain (Sigma-Aldrich Japan) (Briggs, et al. 1996).
- 7) Hybrid of ATP-sensitive potassium channel (K_{ATP}) opener and nitrate: nicorandil (Chugai Pharmac Co, Tokyo) (Uchida, et al. 1978; Yanagisawa, et al. 1979).
- 8) K_{ATP} opener: pinacidil (Wako) (Davis, et al. 2010).
- 9) K_{ATP} inhibitor: glibenclamide (Wako) (Medina, et al. 2010; Lindauer, et al. 1989).
- 10) Drugs that affect the sarcoplasmic reticulum (SR): caffeine (Wako) (Somlyo and Somlyo AP, 1976); dantrolene (Wako) (Kuba, 1980).
- 11) Drugs that affect the mitochondria: oligomycin (Sigma-Aldrich Japan) (Visneskii, et al. 1980).
- 12) Beta-adrenergic receptor agonist: isoproterenol (Sigma-Aldrich Japan) (Prtkov and Nelson, 2005).
- 13) Beta-adrenergic receptor blocker: propranolol (Wako) (Romana-Rouza, et al. 2009).
- 14) Alpha and beta-adrenergic receptor stimulant: phenylephrine (Wako) (Romana-Rouza, et al. 2009).

JPET #180687

7. Data Presentation

Because PCs of coronary artery rings obtained from the same beagle tend to quite uniform response to a given stimulus (Uchida, 1984), each study group was composed of rings obtained from different beagles, and therefore the number of rings also indicated number of beagles in the present study.

In order to compare the potency of drug effects on PCs, it is necessary to compare their effects, for example, on developed tension, duration of contraction, the area under tension curve, or cycle length of PCs as we reported previously (Uchida, 1984), or to compare maximum percent inhibition or oscillatory response (Watts, et al., 1993). In contrast, because the present study was aimed to examine the effects on PCs of individual drug and not to compare potency among drugs, whether or not a given drug eliminated or recovered with a given dosage was presented.

8. Statistical Analysis

The data were expressed as mean \pm standard deviation (SD) and were tested by Student's *t* test. $A_p < 0.05$ was considered significant.

Results

1. PCs Induced by 3,4-DAP

At 3-30 (21 ± 6) min following administration of 10^{-2} mol/L 3,4-DAP, the isolated coronary arterial rings from the beagles began to contract abruptly, and contracted periodically and spontaneously thereafter in all preparations for more than 12 hours (Fig. 1, and Table 1A).

PCs were only elicited by 3,4-DAP in the presence of CaCl_2 in concentrations between 0.3×10^{-3} and 5×10^{-3} mol/L. They did not appear below or above this range (Table 1B).

The contraction time, cycle length and developed tension were almost constant for 12 hours (Table 1C).

JPET #180687

2. Changes in TMP Induced by 3,4-DAP

The TMP of the smooth muscles of the isolated coronary rings was -48 mV on average before (resting potential) the administration of 10^{-2} mol/L of 3,4-DAP and immediately after it increased to -37 mV, but was not followed by obvious tension development (Table 2A). However, 3 - 30 min later, an abrupt spike-and-plateau depolarization accompanied by tension development occurred (Fig.2A). High speed recording of TMP revealed that a slight depolarization preceded this spike-and-plateau depolarization (a-b in Fig. 2B).

The spike was around 0 mV but the initial portion of the plateau was - 22.5 mV in average. The plateau decreased gradually (slow repolarization) and changed into fine oscillation [(possibly Ca^{2+}) oscillation; arrow O in Fig. 2A)]. When TMP reached to -27.5 mV, an abrupt repolarization occurred and TMP returned to the baseline level (Fig. 2A, Table 2B).

In three of the rings, small and periodic waves were superimposed on the partial depolarization wave that was caused by 3,4-DAP. The cycle length of these waves ranged from 5 s to 5 min and the waves were not accompanied by a spike-and-plateau depolarization and contraction (Fig. 2C), nor were they inhibited by nifedipine, which inhibits Ca_V (Medina, et al. 2010).

3. Effects on PCs of Drugs that May Affect Ion Channels

a) K_{Ca} inhibitors

PCs were lengthened in the contraction phase by lower concentrations and were replaced by tonic contractions (TCs) at higher concentrations of IbTX or ChTX (Latorre, et al. 1989; Marchenko and Sage, 1995), indicating that the relaxation phase (i.e., opening of K_{Ca}) was inhibited by these agents (Fig. 3A and Table 3). However, PCs were not influenced by apamine, which inhibits small-conductance K_{Ca} (Marchenko and Sage, 1995) (Table 3).

b). Calcium ions

CaCl_2 in a concentration $\geq 5 \times 10^{-3}$ mol/L eliminated PCs, and this inhibitory effect was inhibited by IbTX and ChTX, indicating that Ca^{2+} eliminated

JPET #180687

PCs by activating K_{Ca} (Fig. 4, and Table 3).

c) pH

Lowering pH to 7.30 or below with HCl or lactic acid always resulted in elimination of PCs. In contrast, elevation of pH to 7.33 or over with NaOH or NaHCO_3 resulted in the reappearance of PCs (Fig. 5, and Table 4). However, PCs were replaced by tonic contractions (TCs) when pH exceeded 7.8 with NaOH (Tables 4). Lowering pH with lactic acid or increasing percentage of CO_2 in the gas and elevating pH with NaHCO_3 or increasing percentage of O_2 in the gas had the same effects. NaCl had no obvious effects on PCs, indicating that H^+ , OH^- and HCO_3^- affected PCs (Tables 3 and 4).

d) Cav Inhibitors

Nifedipine eliminated PCs as well as spike-and-plateau depolarization at concentrations of 10^{-7} - 10^{-6} mol/L (Fig. 6, and Table 3). Similarly, verapamil eliminated PCs (Table 3).

e) Inhibitors of ion pumps

The PCs were changed into tonic contractions (TCs) by the administration of ouabain (Briggs, et al. 1996) (Fig. 3B and Table 3). However, the TCs thus induced were eliminated by nifedipine and CaCl_2 (Fig. 3C, D).

f) Drugs that affect the SR

Ca^{2+} released from the SR regulates smooth muscle contraction (Quiarrie, et al. 2011), but PCs were not influenced by caffeine, which inhibits the uptake and accelerates the release of Ca^{2+} from the SR (Somlyo and Somlyo AP, 1976) and by dantrolene, which inhibits Ca^{2+} release from the SR (Kuba, 1980)(Table 3).

g) Drug that affects the mitochondria

Ca^{2+} uptake and release by the mitochondria influence contraction. However, PCs were not influenced by oligomycin (Table 3).

JPET #180687

h). K_{ATP} openers

Nicorandil is a hybrid of K_{ATP} opener and nitrate (Uchida, et al. 1978; Yanagisawa, et al. 1979), and PCs were eliminated by administration of 10^{-4} mol/L nicorandil (Table 3). The inhibitory effect of nicorandil on PCs was inhibited not by K_{Ca} inhibitor but by a K_{ATP} inhibitor glibenclamide (Lindauer, et al. 2003) (Table 5). Likewise, the inhibitory effect of pinacidil on PCs was inhibited by glibenclamide (Table 5).

Following administration of 10^{-4} M nicorandil, TMP was lowered (hyperpolarization) and the spike-and-plateau depolarization did not appear (Table 6).

i). Beta-adrenergic receptor agonist

Beta-adrenergic receptors cause smooth muscle relaxation through cAMP. A beta-adrenergic receptor agonist isoproterenol inhibited PCs (Tables 3). The PCs inhibited by isoproterenol (10^{-6} mol/L) were recovered by propranolol (10^{-6} mol/L) in 6 preparations.

Discussion

A number of studies have been performed on the mechanisms of vascular smooth muscle contraction, and roles of endothelium, ion channels, pumps, exchanges, receptors and intracellular factors in vascular smooth muscle contraction have been clarified considerably (Vanhoutte, 2005; Uhrenholt, 2007).

Also, many studies have been performed on the mechanisms of vascular spasm, suggesting participation of endothelial dysfunction (Feletou, 2010), increase of vasoconstricting substances (Vanhoutte, 2005), decrease of vasorelaxing substances (McNeish, 2010), increased calcium influx (Asano, 1993) hypersensitivity of vascular smooth muscles, and genomic changes (Murakami, 2010; Takefuji, 2010). However, exact ion mechanisms of coronary smooth muscle spasm, especially of periodic spasm and its pH-sensitive nature, have remained obscure.

JPET #180687

In the present in-vitro study, 3,4-DAP, a K_V inhibitor, elicited PCs of coronary smooth muscles. Cycle length of PCs and pH-sensitive nature were similar to those of coronary spasm in patients with vasospastic angina (Muraio, et al. 1975; Uchida, 1984).

Based on the results of present study, the following ion mechanisms are considered to participate in 3,4-DAP-induced PCs:

1. Participation of K_{Ca} in PCs

Administration of 3,4-DAP elevated TMP, indicating partial depolarization to some extent. The depolarization consisted of a rapid component, which occurred immediately after drug administration, and a following very slow component, indicating that the K_V was partially closed (inhibited) abruptly and then slowly closed thereafter. When TMP reached to a certain level, a small depolarization occurred (b in Fig. 7). Although the exact interactions between K_V and K_{Ca} were not examined, this relatively slow depolarization that preceded the spike-and-plateau depolarization might be related to closing (inhibition) of the K_{Ca} , and it triggered the opening (activation) of Ca_V , and consequent $Ca(2+)$ influx, leading to the spike-and-plateau depolarization and contraction (Figs.7, 8).

The small and periodic depolarization waves that were not accompanied by a spike-and-plateau depolarization were observed in a few preparations, It was considered to be the result of a coupling failure between the K_{Ca} and Ca_V .

In high concentrations, $Ca(2+)$ eliminated PCs, and the PCs were restored by IbTX and ChTX, which inhibit large-conductance K_{Ca} (Miller, et al. 1985). Furthermore, PCs were replaced by TCs by the administration of IbTX and ChTX. However, apamine, which inhibits small-conductance K_{Ca} did not influence PCs (Muraki, et al. 1997). Taken together, it is conceivable that large-conductance K_{Ca} plays an important role in the genesis of PCs.

PCs were elicited by 3,4-DAP within a limited range of $CaCl_2$ concentrations, which indicates that $Ca(2+)$ in lower concentrations caused contraction and in high concentrations eliminated contractions by opening (activating) K_{Ca} .

The spike-and-plateau depolarization mimics those of the mesenteric

JPET #180687

arterial smooth muscles of rat (Chen and Khalil, 2008), and pregnant uterine muscles which are contracted by ergonovine, which is used clinically to provoke coronary spasm (Osa and Ogasawara, 1984).

3. Role of L-type Ca_v

The spike-and-plateau depolarization, as well as PCs, were eliminated by nifedipine. We therefore considered that the spike-and-plateau depolarization was caused by calcium influx through the L-type Ca_v (Figs. 7, 8). In this respect, PCs in the present study differ from $\text{Ca}(2+)$ -insensitive vascular contraction (McNail, 2004).

4. Role of pH

In the present study, the PCs were extremely sensitive to changes in pH; PCs were eliminated by lowering the pH with $\text{H}(+)$ or CO_2 , and the PCs reappeared by elevating the pH with $\text{OH}(-)$, $\text{HCO}_3(-)$, or O_2 . Furthermore, PCs eliminated by $\text{H}(+)$ were restored by IbTX and ChTX which inhibit large-conductance K_{Ca} , indicating that $\text{H}(+)$ acted as an opener of large-conductance K_{Ca} (Figures 7, 8).

Smooth muscle contraction results in the production of $\text{H}(+)$ by mitochondria and $\text{H}(+)$ is released into the cytoplasm (Somlyo & Somlyo AP. 1976). In addition to the influx of extracellular $\text{H}(+)$ into the cell, the $\text{H}(+)$ released from mitochondria might have contributed to the relaxation phase of PCs by the opening of K_{Ca} .

Since NaOH and NaHCO_3 also restored the PCs that were suppressed by $\text{H}(+)$, and since $\text{OH}(-)$ and $\text{HCO}_3(-)$ induced TCs were eliminated by $\text{Ca}(2+)$, which activates K_{Ca} , and nifedipine, $\text{OH}(-)$ and $\text{HCO}_3(-)$ might have acted as closers (inhibitors) of K_{Ca} (Fig. 8).

5. Roles of Ion Exchangers and Pumps

In addition to the $\text{Ca}(2+)$ pump, the $\text{Na}(+)$ - $\text{Ca}(2+)$ exchanger plays a role in the exclusion of intracellular $\text{Ca}(2+)$. In the present study, PCs were replaced by TCs after the administration of ouabain, which inhibits the $\text{Na}(+)$ - $\text{K}(+)$ pump through inhibition of the $\text{Na}(+)$ - $\text{K}(+)$ ATPase, which is

JPET #180687

coupled to the Na(+)-Ca(2+) exchanger (Kim, et al. 2005; Prichard, et al. 2010). Interestingly, however, the TCs induced by ouabain were eliminated by CaCl₂ and nifedipine, suggesting that ouabain elicited TCs not by acting on its target ion pump but by closing K_{Ca}.

6. Role of SR

The SR is the Ca(2+) storage site. The PCs were not inhibited by caffeine, which inhibits uptake and accelerates release of Ca(2+) from the SR (Somlyo and somlyo AP, 1976) and dantrolene which inhibits Ca(2+) release from SR (Kuba, 1980), indicating that intracellular Ca(2+) not from the SR but from other sites such as the extracellular space mainly contributed to eliciting PCs, as in case of nitric oxide production by vascular endothelial cells (Rusco, et al. 1992).

7. Role of the Mitochondria

Because oligomycin which inhibits Ca(2+) movement from the mitochondria (Visneskii, et al. 1980), did not affect PC, it is unlikely that Ca(2+) supplied from the mitochondria participated in eliciting PCs.

8. Role of K_{ATP}

Nicorandil, a hybrid of K_{ATP} opener and nitrate, also inhibited PCs, and its inhibitory effect was not blocked by K_{Ca} inhibitors but was blocked by glibenclamide, a K_{ATP} inhibitor (Lindauer, et al. 2003). Because nicorandil caused hyperpolarization of the cell membrane in the present and previous studies (Yanagisawa, et al. 1979), the rise in TMP necessary for K_{Ca} closing or opening of Ca_V was prevented by this agent, with resultant inhibition of PCs.

9. Role of Beta-adrenergic Receptors

Isoproterenol, a beta-adrenoceptor stimulant, eliminated PCs, probably through activation of cAMP because propranolol blocked the inhibitory action of isoproterenol on PCs, although activation of K_{Ca} can not be denied (Petkov and Nelson, 2005).

JPET #180687

10. Possible Underlying Mechanisms of PCs

Pulling all the results together, the following is the mechanism that we considered to be involved in the induction of PCs by 3,4-DAP.

3,4-DAP caused a partial depolarization of TMP by closing (inhibiting) K_V . When TMP reached to a threshold potential, the K_{Ca} closed, resulting in a slight depolarization. (arrow b in Fig 7). When TMP attained the threshold level by this depolarization, coupled by K_{Ca} , the L-type Ca_V opened and an abrupt $Ca(2+)$ influx occurred, with resultant spike-and-plateau depolarization and contraction. When the intracellular $Ca(2+)$ concentration, i.e., $[Ca(2+)]_i$, reached to a certain level by this influx, $Ca(2+)$ itself opened the large conductance K_{Ca} with resultant closing of Ca_V and consequent repolarization and relaxation.

Stimulated by this process, $Ca(2+)$ efflux was induced through the $Na(+)$ - $Ca(2+)$ exchanger and/or $Ca(2+)$ pump, and $H(+)$ efflux through the $Na(+)$ - $H(+)$ exchanger. The $K(+)$ - $Na(+)$ pump might also participated in this process by regulating the $K(+)$ - $Na(+)$ exchanger or $H(+)$ - $Ca(2+)$ exchange (Prichard, et al. 2010). When $Ca(2+)$ was considerably excluded, K_{Ca} closed again and the processes were repeated, resulting in PCs (Fig. 7, 8).

It is conceivable that intracellular $Ca(2+)$ played a key role in PCs, although channels, exchangers and receptors other than those mentioned above might have affected PCs through, or not through, altering TMP (Figs. 7, 8).

11. Possible Mechanism of Periodic Nature of Coronary Artery

Periodic nature of 3,4-DAP-induced contraction of a single smooth muscle cell can be explained by the above-mentioned mechanism. PCs observed in the present study indicated simultaneous contraction of the smooth muscle cells that constituted the ring. However, why multiple smooth muscles contracted simultaneously remains to be elucidated.

Oscillatory contractions can be induced in rat tail or mesenteric artery by sympathetic denervation or tetraethylammonium chloride. An increased cell-to-cell communication by increased gap expression has been proposed as the underlying mechanism of the oscillatory contractions (Slovt, 2004; Watts,

JPET #180687

1994). Similar mechanism may underlay the PCs observed in the present study.

12. Similarity and Dissimilarity to PCs in the Other Arteries

Periodic or rhythmic contractions are produced in the human vas deferens by Bay K 8644, which is blocked by nifedipine and verapamil (Amobi, et al. 2010). Burke, et al. also observed PCs of the rat pulmonary artery induced by phenylephrine and Bay K8644 (Burke, et al. 2010). In the present study, however, PCs was not induced by BayK8644 while they were suppressed by phenylephrine. Giatini, et al. observed rhythmic contractions of mouse mesenteric artery induced by phenylephrine in the presence but not in the absence of the endothelium (Gianchini, et al. 2009). The 3,4-DAP-induced PCs occur irrespective of the presence or absence of the endothelium (Uchida, 1984), indicating that the PCs in the present study are different from the rhythmic contractions observed by Burke, and Giatini, et al.

13) Clinical Implications

Clinically, in patients with vasospastic angina the attacks caused by coronary spasm often occur periodically with a cycle length ranging in minutes. The attacks are evoked by elevating blood pH and inhibited by lowering blood pH. Based on the results presented in this study, 3,4-DAP-induced PCs in isolated canine coronary artery rings appear to share some characteristics in common with human coronary vasospasm in respect to periodic nature and pH-sensitive nature.

Study Limitations

To analyze electrophysiological properties of K_{Ca} by patch clamp method is necessary to obtain definite evidence of periodic closing and opening of K_{Ca} which were considered to underlay the PCs.

JPET #180687

Conclusions

PCs of beagle coronary smooth muscles were elicited by 3,4-DAP which inhibits K_V . The cycle length and pH-sensitive nature of PCs was similar to those of coronary spasm in patients with vasospastic angina.

We considered that closing of K_V induced by 3,4-DAP resulted in closing of K_{Ca} and consequent opening of L-type Ca_V , leading to $Ca(2+)$ influx and contraction, and the increased intracellular $Ca(2+)$ by this influx opened K_{Ca} and consequent Ca_V closure and relaxation, and these processes were repeated spontaneously, resulting in PCs, and that $H(+)$ that was produced by mitochondria acted as a K_{Ca} opener.

Authorship Contributors

Participated in research design: Uchida,

Participated in Research (acquired data): Uchida Y, Maezawa,
Maezawa Y, Nakamura.

Performed data analysis: Maezawa.

Wrote manuscript: Uchida.

JPET #180687

References

- Amobi N, Guillebaud J, Smith IC., (2010), Contractile actions of L-type Ca^{2+} agonists in human vas deferens and effects of structurally different Ca^{2+} antagonists. *Eur J Pharmacol* 627: 285-294.
- Briggs AH, Shibata Y, Tomita T., (1996), Ca and ouabain interactions on vascular smooth muscle. *Proc Soc Exp Med*. 121: 274.
- Burke MM, Bieger D, Tabrizchi R., (2010), Agonist-induced periodic vasomotion in rat isolated pulmonary artery. *Fundam Clin Pharmacol* 55:23-30.
- Chen W, Khalil RA.,(2008), Differential $\{\text{Ca}^{2+}\}$ signaling of vasoconstriction in mesenteric microvessels of normal and reduced uterine perfusion pregnant rats. *Am J physiol Regul Integr Comp Physiol* 295: R1262-1272.
- Davies LM, Pulves GI, Barret-Jolly R, Dart C., (2010), Interaction with caveolin-1 modulates vascular ATP-sensitive potassium (K_{ATP}) channel activity. *J Physiol* 558: 3255-3266.
- Feletou M, Kohler R, Vanhoutte PM., (2010), Endothelium-derived vasoactive factors and hypertension: possible roles in pathogenesis and as treatment targets. *Curr hypertension Rep*. 12: 267-275.
- Flet L, Polard E, Guillard O, Laray E, Allain H, Javaudin L, Edan G.,(2010), 3,4-diaminopyridine safety in clinical practice: an observational, retrospective cohort study. *J Neurol* 257: 937-946.
- Fukai T, Egashira K, Hata H, Numaguchi K, Ohara Y, Takahashi T, Tomoike H, Takeshita A., (1993), Serotonin-induced coronary spasm in a swine model. A minor role of defective endothelium-derived relaxing factor. *Circulation*. 88: 1922-1930.
- Giachini FR, Carneiro FS, Lima VV, Carneiro ZN, Brands MW, Webb RC, Tostes RC., (2009), A key role for $\text{Na}^{+}/\text{K}^{+}$ -ATPase in the endothelium-dependent oscillatory activity of mouse small mesenteric arteries. *Braz J Med Res*. 42: 1058-1087.
- Harder DR., (1980), Membrane electrical effects of histamine on vascular smooth muscle of canine coronary artery. *Circ Res*. 46: 372-377.
- Hou S, Horrigan FT, Xu R, Heinemann SH, Hoshi T., (2009), Comparative

JPET #180687

- effects of H⁺ and Ca²⁺ on large-conductance Ca²⁺ and voltage-gated Slo1 K⁺ channels. *Channels*. 3: 249-258.
- Joris I, Majno G., (1981), Medial changes in arterial spasm induced by L-norepinephrine. *Am J Pathol*. 105: 212-222.
- Kim MY, Seol GH, Liang GH, Kim JA, Suh SH., (2005), Na⁺-K⁺ activation inhibits endothelium-dependent relaxation by activating the forward mode of Na⁺-Ca²⁺ exchanger of mouse aorta. *Am J Physiol Heart Circ Physiol*. 289: H2020-2029.
- Kirsch GE, Narahashi T., (1978); 3,4-Diaminopyridine. A potent potassium channel blocker. *Biophys J*. 22: 507-512.
- Kiyoshi H, Yamazaki D, Ohya S, Kitsukawa M, Muraki K, Saito S, Ohizumi Y, Imaizumi Y., (2006), Molecular and electrophysiological characteristics of K⁺ conductance sensitive to acidic pH in aortic smooth muscle cells of WKY and SHR. *Am J Physiol Heart Circ Physiol*. 291: H2723-2734.
- Ko EA, Park WS, Son YK, Ko JH, Choi TH, Jung ID, Park YM, Hong da H, Kim N, Han J., (2010), Calcium channel inhibitor, verapamil, inhibits the voltage-dependent K⁺ channels in rabbit coronary smooth muscle cells. *Biol Pharm Bull*. 33: 47-52.
- Kuba K., (1980), Release of calcium ions linked to the activation of potassium conductance in caffeine-treated sympathetic nerves. *J Physiol (Lond)*. 298: 251-269.
- Latorre R, Oberhauser A, Labarca P, Alvarez O., (1989), Varieties of calcium activated potassium channels. *Ann Rev Physiol*. 51: 385-399.
- Lindauer U, Vogt J, Schu-Hofer S, Dreier JP, Dimalgl U., (2003), Cerebrovascular vasodilation to external acidosis occurs via combined activation of ATP-sensitive and Ca²⁺-activated potassium channels. *J Cereb Blood Flow Metab*. 23: 1227-1238.
- Marchenko SM, Sage SO., (1995), Calcium-activated potassium channels in the endothelium of intact rat aorta. *J Physiol*. 492: 53-60.
- Maseri A, Abbate AL, Bardori G., (1978), Coronary vasospasm as a possible cause of myocardial infarction. *N Eng J Med*. 229: 1271-1278.
- McNail LL, Salamanca DA, Khalil RA., (2004), Endothelin-1 promotes Ca²⁺-antagonist-insensitive coronary smooth muscle contraction via activation of epsilon-protein kinase C. *Hypertension*. 43: 897-904.

JPET #180687

- McNeish AJ, Altayo FJ, Garland CJ., (2010), Evidence both L-type and non-L-type voltage-dependent calcium channels contribute to cerebral artery vasospasm following loss of NO in the rat. *Vascul Pharmacol* 53: 151-159.
- Medina P, Segarra G, Mauricio MD, Vila JM, Chuan P, Lluch S., (2010), Modulation of adrenergic responses of human vas deferens by K⁺ channel inhibitors. *Urology*. 1518 e 7-12.
- Miller C, Moczydlowski E, Latorre R, Phillips M., (1985), Charybdotoxin, a protein inhibitor of single Ca²⁺- activated K⁺ channels from mammalian skeletal muscle. *Nature*. 313: 316-318.
- Mitsuoka W, Egashira S, Tagawa H, Kuga T, Hayashi Y, Yamada A, Tomoike H, Nakamura M, Takeshita A., (1995), Augmentation of coronary responsiveness to serotonin at the site of X-ray-induced intimal thickening in miniature pigs. *Cardiovasc Res*. 30: 246-254.
- Murakami R, Osanai T, Tomita H, Sasaki S, Maruyama A, Itoh K, Homma Y, Okumura K., (2010), p122 protein enhances intracellular calcium increase to acetylcholine: its possible role in the pathogenesis of coronary spastic angina. *Arterioscler Thromb Vasc Biol*. 30: 1968-1975.
- Muraki K, Imaizumi Y, Ohya S, Sato K, Takii T, Onozaki K, Watanabe M., (1997), Apamine-sensitive Ca²⁺-dependent K⁺ current and hyperpolarization in human endothelial cells. *Biochem Biophys Res Comm*. 236: 340-343.
- Murao S, Harumi K, Mashima S., (1975), Clinical and experimental study on the mechanism of variant angina pectoris. *Jpn J Med*. 14: 15.
- Osa T, Ogasawara T., (1984), Changes in the adrenergic effects of membrane activity of the circular muscle of rat uterus during late pregnancy and postpartum. *Jpn J Physiol* 34: 113-129.
- Petkov GV, Nelson MT., (2005), Differential regulation of Ca²⁺- activated K⁺ channels by beta-adrenoceptors in guinea pig urinary bladder smooth muscle. *Am J Physiol Cell Physiol*. 288: C1255-1263.
- Prichard TJ, Bowman PS, Jefferson A, Tosun M, Lynch RM, Paul RJ., (2010), Na(+)-K(+)-ATPase and Ca(+) clearance proteins in smooth muscle: a functional unit. *Am J Physiol Heart Circ Physiol* 299: H548-556.
- Prinzmetal M, Kenner R, Merliss E., (1959), Angina pectoris. I. A variant form of angina pectoris. *Am J Med*. 27: 375-378.
- Quarrie R, Cramer BM, Lee DS, Steinberg GE, Erdahl W, Pfeiffer DR,

JPET #180687

- Zweier JL, Crestanello JA., (2011), Ischemic preconditioning decreases mitochondrial proton leak and reactive oxygen species production in the postischemic heart. *J Surg Res.* 165: 5-14.
- Robertson, BE, Nelson MT., (1994), Aminopyridine inhibition of voltage dependence of K⁺ currents in smooth muscle cells from cerebral arteries. *Am J Physiol.* 267: C1589-1597.
- Romana-Souza B, Santos JS, Monte-Alto-Costa A., (2009), Beta-1 and beta-2, but not alpha-1 and alpha-2, adrenoceptor blockade delays rat cutaneous wound healing. *Wund Healing Regen.* 17: 230-239.
- Rusko J, Taniz F, van Greemen C, Adams DJ., (1992), Calcium-activated potassium channels in native endothelial cells from rabbit aorta: conductance, Ca²⁺ sensitivity and block. *J Physiol.* 455: 601-621.
- Siegel W., (2010), The first provocative test for coronary artery spasm at the Cleveland Clinic. *Am J Cardiol.* 105: 1198-1199.
- Slovut DP, Mehta SH, Dorrance AM, Brosius FC, Watts SW, Webb RC., (2004), Increased vascular sensitivity and connexin43 expression after sympathetic denervation. *Cardiovasc Res.* 62: 388-396.
- Somlyo AV, Somlyo AP., (1976), Strontium accumulation by sarcoplasmic reticulum and mitochondria in vascular smooth muscles. *Pharmac Rev.* 925: 501-510.
- Takefuji M, Asano H, Mori K, Amano M, Kato K, Kaibuchi K., (2010), Mutation of ARHGAP9 in patients with coronary spastic angina. *J Hum Genet.* 55: 42-49.
- Tsunemi T, Ishikawa K, Tsutsui K, Sumi T, Kitamura K, Mizusawa H., (2010), The effect of 3,4-diaminopyridine on the patients with hereditary pure cerebellar ataxia. *J Neurol Sci.* 292: 81-84.
- Uchida Y.,(1984) Decreasing potassium conductance, a possible mechanism of phasic coronary spasm. *Circ J.* 63: 128-139.
- Uchida Y, Sugimoto, T., (1985), Decreasing potassium conductance: a possible mechanism for development of coronary vasospasm. *Federation proceeding.* 43: 358.
- Uchida Y, Yoshimoto N, Murao S., (1978), Effects of 2-nicotinamidoethynitrate (Nicorandil) on coronary circulation. *Jpn Heart J.* 39:112-114.

JPET #180687

- Uchida Y, Uchida Y, Matsuyama A, Koga A, Maezawa Y, Maezawa Y, Hiruta N., (2011), Functional medial thickening and folding of the internal elastic lamina in coronary spasm. *Am J Physiol Heart Circ Physiol* 300: 423-430.
- Uhrenholt TR, Schjeming J, Vanhoutte PM, Jensen BL, Shott O., (2007), Intercellular calcium signaling and nitric oxide feedback during constriction of rabbit renal afferent arterioles. *Am J Physiol Renal Physiol*. 292: 1124-1131.
- Vanhoutte PM, Feletou M, Taddel S., (2005), Endothelium-dependent contractions in hypertension. *Br J Pharmacol* 144: 449-458.
- Visneskii ES, Brzhevskaja ON, Nedelina OS, Sheksheev EM, Kaiushin LP., (1980), Detection of a pharmacodynamic product developing during oxidative phosphorylation in mitochondria. *Biofizika*. 25: 740-741.
- Watts SW, Traub O, Lamb FS, Myers JH, Webb RC., (1993), Effect of ramipril on alpha-adrenoceptor-mediated oscillatory contractions in tail artery of hypertensive rats. *Eur J Pharmacol* 242: 245-253.
- Watts SW, Tsai ML, Loch-Caruso R, Webb RC., (1994) Gap junctional communication and vascular smooth muscle reactivity: use of tetraethylammonium chloride. *J Vasc Res*. 31: 307-313.
- Yamamoto Y, Tomoike H, Egashira K, Kobayashi T, Kawasaki T, Nakamura M., (1987), Pathogenesis of coronary artery spasm in miniature swine with regional intimal thickening after balloon denudation. *Circ Res*. 60: 113-121.
- Yanagisawa T, Sato T, Taira N., (1979), Circumferential evidence for increased potassium conductance of membrane of cardiac muscle by 2-nicotinamidoethyl nitrate. *Jpn J Pharmacol* 29: 687-696.
- Yasue H, Nagao M, Omote M., (1978), Coronary arterial spasm and Prinzmetal's variant form of angina induced by hyperventilation and Tris-buffer infusion. *Circulation* 58: 56-61.

JPET #180687

Figure Legends

Fig. 1. Periodic Contractions (PCs) of Coronary Smooth Muscles.

From a to d: Continuous recordings of typical PCs in a coronary ring for more than 10 hours.

Fig. 2. Changes in Transmembrane Potential (TMP)

- A: Simultaneous recording of changes in tension and transmembrane potential (TMP). A spike-and-plateau depolarization was accompanied by tension development. O: oscillation.
- B. High-speed recording of the early phase of depolarization. A small rise in TMP precedes the spike-and-plateau depolarization (arrows a and b).
- C. Slow and periodic depolarizations that were not followed by spike-and-plateau depolarization (arrow), nor associated with tension development.

Fig.3. Effects on Periodic Contractions (PCs) of Inhibitors of Calcium-activated Potassium Channels (K_{Ca}), Ion Pumps and Ion Exchangers

- A: Effects on PCs of iberiotoxin (IbTX), a large-conductance K_{Ca} inhibitor.
- B: Effects on PCs of ouabain, a $Na(+)-K(+)$ pump inhibitor.
PCs were changed to tonic contractions (TCs) by these drugs.
- C. The TCs elicited by ouabain were eliminated by nifedipine.
- D. The TCs elicited by ouabain were eliminated by $CaCl_2$.

Fig.4. Effects on Periodic Contractions (PCs) of $CaCl_2$ and Large-conductance K_{Ca} Inhibitors

- A: PCs eliminated by 5×10^{-3} mol/L $CaCl_2$.
- B. PCs that were eliminated by $CaCl_2$, were restored by 10^{-8} mol/L IbTX, but the contraction phase was longer than that before $CaCl_2$ administration.
- C. Administration of 10^{-7} mol/L IbTX during inhibition of PCs by $CaCl_2$ evoked TCs.

JPET #180687

Fig. 5. Relationship between pH and Periodic Contractions (PCs)

Effects of stepwise changes in pH on PCs. pH and PCs were recorded simultaneously. PCs were eliminated by lowering pH to 7.23 with HCl and were restored by elevating pH to 7.33 with NaOH.

Fig. 6. Effects on Periodic Contractions (PCs) and Transmembrane Potential (TMP) of Nifedipine, A L-type C_{av} Inhibitor

- A: Effects on PCs of stepwise increase in the concentration of nifedipine. PCs were eliminated with 10^{-6} mol/L nifedipine.
- B: Effects on TMP and PCs of nifedipine. Both the spike and plateau depolarization and contraction were eliminated by nifedipine.

Fig. 7. Possible Mechanisms of Periodic Contractions (PCs)

3,4-DAP, a K_{Ca} blocker with 3,4-DAP causes a partial depolarization of the cell membrane, which results in closing of the K_{Ca} and consequent further depolarization (arrow b). This second depolarization triggers the opening of L-type voltage-dependent calcium channels (C_{av}) and consequent spike and plateau depolarization because of the $Ca(2+)$ influx and development of contraction. When intracellular $Ca(2+)$ concentration, i.e., $[Ca(2+)]_i$, is increased to a certain level, $Ca(2+)$ causes opening of the K_{Ca} and consequent repolarization, which leads to closing of C_{av} and cessation of $Ca(2+)$ influx, and thus relaxation. Triggered by this process, $Ca(2+)$ is extruded through the $Ca(2+)$ pump and the $Na(+)-Ca(2+)$ exchanger. The $Na(+)-K(+)$ pump also influences $Ca(2+)$ movements by modifying the $Na(+)-Ca(2+)$ exchanger. Thus, $[Ca(2+)]_i$ decreases and K_{Ca} are closed again, and the same processes are repeated to produce PCs. Contraction results in production and release of $H(+)$ by the mitochondria and the increased concentration of intracellular $H(+)$, i.e., $[H(+)]_i$ acts as an opener of K_{Ca} . Many other receptors, channels, exchangers, and pumps and intracellular mechanisms may also influence the development and maintenance of PCs.

JPET #180687

**Fig. 8. Possible Ion Movements Associated with Periodic Contractions (PCs)
and the Site of Actions of Drugs**

**[Ca(2+)]_i : concentration of intracellular Ca(2+). [H(+)]_i : concentration
of intracellular H(+).**

JPET #180687

Table 1. Periodic Contractions (PCs) of Coronary Smooth Muscles Induced by 3,4-Diaminopyridine (3,4-DAP)

A. Relationships between Concentration of 3,4-DAP and PCs

n=10	3,4-DAP cumulative concentration (mol/L)				
	0	10 ⁻⁴	5x10 ⁻³	10 ⁻²	2x10 ⁻²
PCs evoked	0	0	1	10	3
TCs evoked	0	0	0	0	7

n: number of rings examined. Each ring was obtained from different beagle and therefore the number of rings also indicates the number of beagles in this and in the following tables. PCs: periodic contractions. TCs: tonic contractions.

B. Relationships between PCs Evoked by 10⁻²mol/L 3,4-DAP and CaCl₂ Concentration

	CaCl ₂ concentration (mol/L)							
	0	0.15x10 ⁻³	0.30x10 ⁻³	0.75x10 ⁻³	10 ⁻³	1.5x10 ⁻³	5x10 ⁻³	10 ⁻²
PCs evoked	0	0	4	6	6	6	3	0

Six rings were tested in each CaCl₂ concentration.

C. Time - course Changes in PCs

n= 9	Time from appearance of PCs (hours)			
	1	3	6	12
Cycle length (min)	6.2±3.3	7.4±2.8	8.1±3.5	8.3±4.4
Duration of contraction (min)	3.8±2.4	4.2±2.4	6.1±2.9	5.0±2.4
Developed tension (g)	4.2±1.2	3.6±1.1	3.6±1.1	3.3±0.7

n: no. of rings examined.

JPET #180687

Table 2. Transmembrane Potential (TMP)

A. Changes in TMP Induced by 3,4-DAP

	3,4-DAP cumulative concentration (mol/L)				
	n	0	10 ⁻⁴	10 ⁻³	10 ⁻²
TMP (mV)	10	-48 ± 2	-44 ± 2*	-40 ± 4**	-36.0 ± 5***
Periodic depolarization		0	0	1	10

n: no of rings tested. * p<0.05, ** p<0.01, *** p<0.001 vs 0 M.

B. Periodic Spike-and-plateau Depolarization Induced by 10⁻² mol/L 3,4-DAP

	n	Before depo	Slow depo	Spike	Plateau	Before repo	After repo
TMP (mV)	10	-36.0 ± 5	-30.1 ± 7	-16.8 ± 8	-22.5 ± 5	-27.5 ± 5	-35 ± 4

n: no. of rings examined. depo: depolarization. repo: depolarization.

JPET #180687

Table 3. Effects of Drugs on Periodic Contractions (PCs)

	n	Cumulative concentrations of drugs (mol/L)								
		10 ⁻⁸	10 ⁻⁷	10 ⁻⁶	10 ⁻⁵	10 ⁻⁴	5x10 ⁻³	10 ⁻³	10 ⁻²	5x10 ⁻²
1) K_{Ca} inhibitor										
IbTX	7	1 ^t	3 ^t	4 ^{el}						
ChTX	7	1 ^t , 3 ^{el}	6 ^{el}							
Apamine	5				-	-	-			
2) K(+)-Na(+) pump inhibitor										
Ouabain	6			-	3 ^t	3 ^t				
3) CaCl₂										
CaCl ₂	7					-	3 ^e	4 ^e		
NaCl	3						-	-		
4) Ca_v inhibitor										
Nifedipine	7	-	4 ^e	3 ^e						
Verapamil	6	-	3 ^e	3 ^e						
5) K_{ATP} opener and hybrid of K_{ATP} opener and nitrate										
Pinacidil	5			-	1 ^e	4 ^e				
Nicorandil	7				-	7 ^e				
6) SR inhibitors										
Caffeine	5				-	-				
Dantolorene	5				-	-				
7) Mitochondria inhibitor										
Oligomycin	5				-	-	-			
8) Beta-adrenergic receptor stimulant and blocker										
Isoproterenol	6		-	5 ^e	1 ^e					
Propranolol			-	-	-	-				

JPET #180687

9) Alpha- and beta-adrenergic receptor stimulant

Pheny - 5 2^e 3^e
lephrine

n: no. of rings with PCs before drug administration.

- : no effects.

e: no. of rings in which PCs were eliminated.

t: no. of rings in which PCs were replaced by tonic contractions.

el: no. of rings in which PCs were present but with an elongated contraction phase.

JPET #180687

Table 4. Effects of Changing pH on Periodic Contractions (PCs)

	n	pH							
		6.6	6.8	7.0	7.2	7.4	7.6	7.8	8.0
HCl / NaOH	8	0	0	0	6 ^p	8 ^p	8 ^p	7 ^t	
Lactic acid / NaHCO ₃	6	0	0	0	3 ^p	6 ^p	6 ^p	6 ^t	
CO ₂ / O ₂	5	0	0	0	1 ^p	5 ^p	4 ^p , 1 ^t	5 ^t	

pH was lowered by HCl, lactic acid or by increasing %CO₂, and was elevated by NaOH, NaHCO₃ or by increasing %O₂ of gas.

n: no. of rings examined. p: no. of rings with PCs. t: no. of rings with tonic contractions (TCs).

JPET #180687

Table 5. Recovery of Periodic Contractions (PCs) by Potassium Channel Inhibitors

		Inhibitors			
		IbTX	ChTX	NaOH	Glibencramide
Concentration (mol/L)		10^{-7}	10^{-8}	5×10^{-3}	10^{-6}
Suppressors	n				
of PCs					
HCl	5	4 ^r ,1 ^t	3 ^r ,2 ^t	5 ^r	0
(2 × 10 ⁻³ mol/L)					
CaCl ₂	5	4 ^r ,1 ^t	4 ^r ,1 ^t	5 ^r	0
(5 × 10 ⁻³ mol/L)					
Nicorandil	5	0	0	0	5 ^r
(10 ⁻⁴ mol/L)					
Pinacidil	5	0	0	0	5 ^r
(10 ⁻⁵ mol/L)					

n: no of rings used for each examination. PCs that were previously eliminated by suppressors, were either recovered (r) or TCs were provoked (t) by the inhibitors.

JPET #180687

Table 6. Effects of Nifedipine and Nicorandil on Periodic Contractions (PCs) and Transmembrane Potential (TMP)

	n	PCs eliminated	Changes in TMP (mV)
Nifedipine (10^{-6} mol/L)	5	5	+0.3 ± 0.5
Nicorandil (10^{-4} M)	5	5	- 15.1 ± 5

n: no. of rings examined.

JPET #180687

Table 7. Elimination of Tonic Contractions (TCs) by Nifedipine and CaCl₂

Concentration (mol/L)		Nifedipine 10 ⁻⁶	CaCl ₂ 5 × 10 ⁻³
	n		
Inducers of TCs			
NaOH (10 ⁻³ mol/L)	4	4 ^e	
	4		4 ^e
Ouabain (10 ⁻⁵ mol/L)	5	5 ^e	
	5		5 ^e

n: no of rings examined. **e:** eliminated.

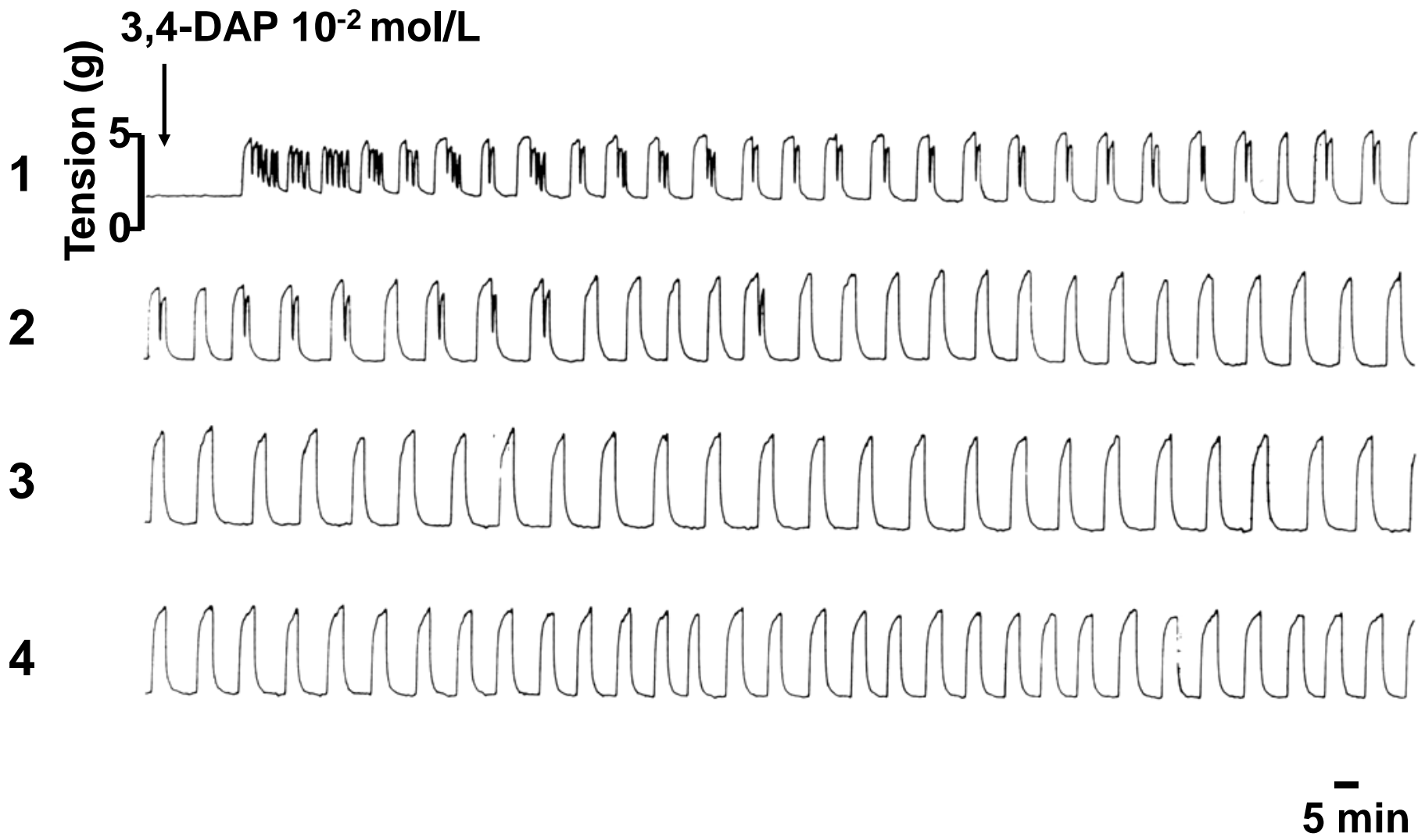

Fig. 1

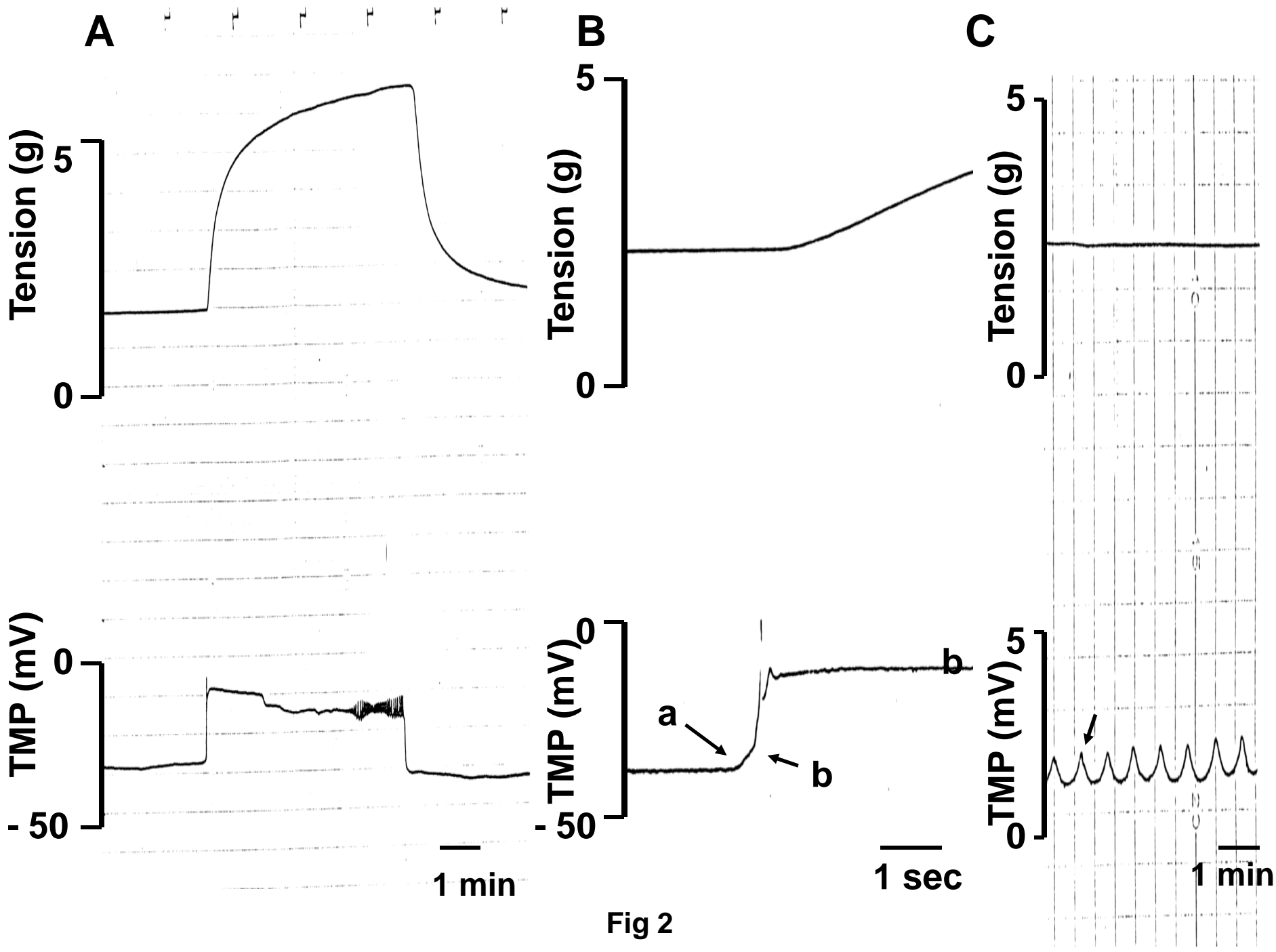

Fig 2

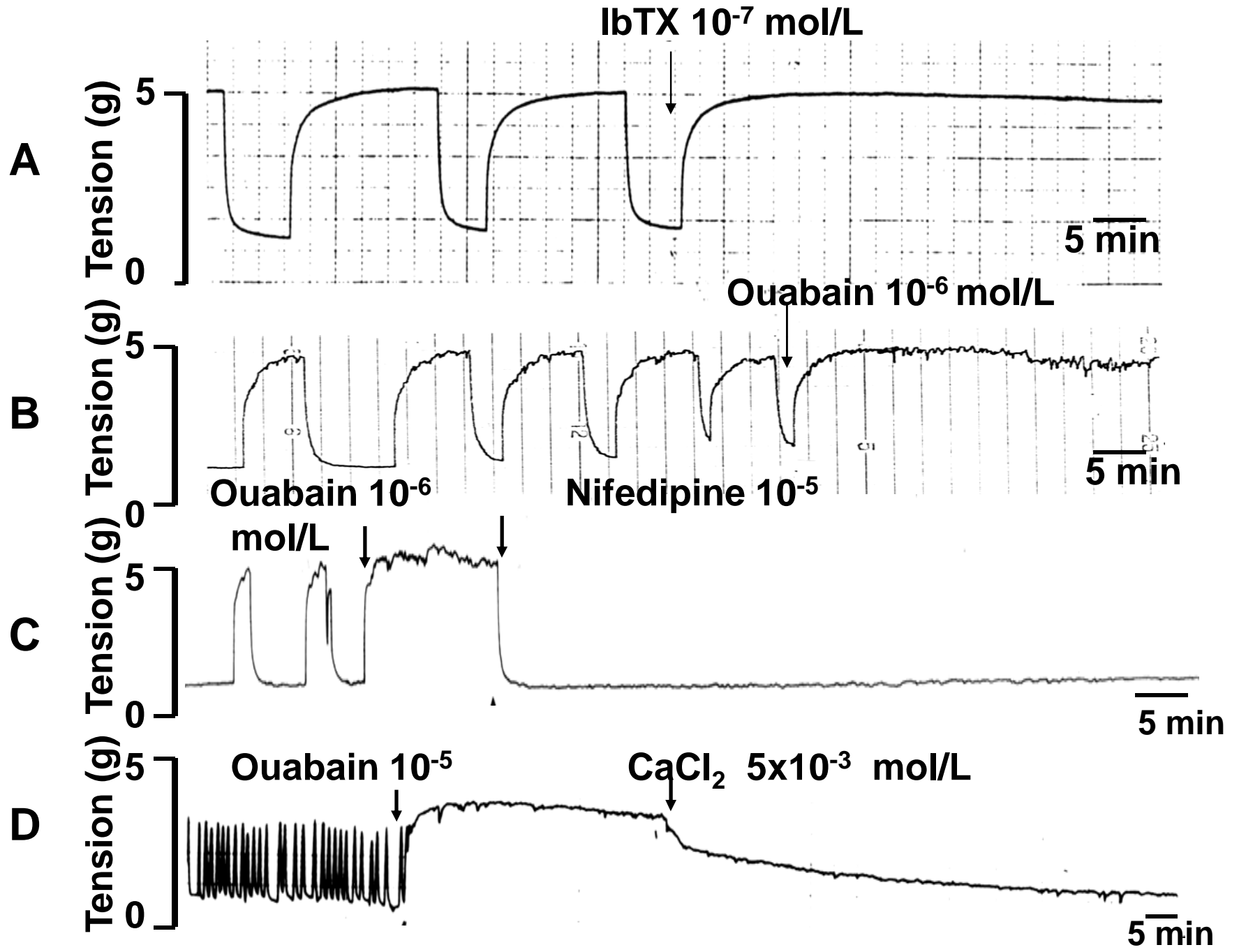

Fig. 3

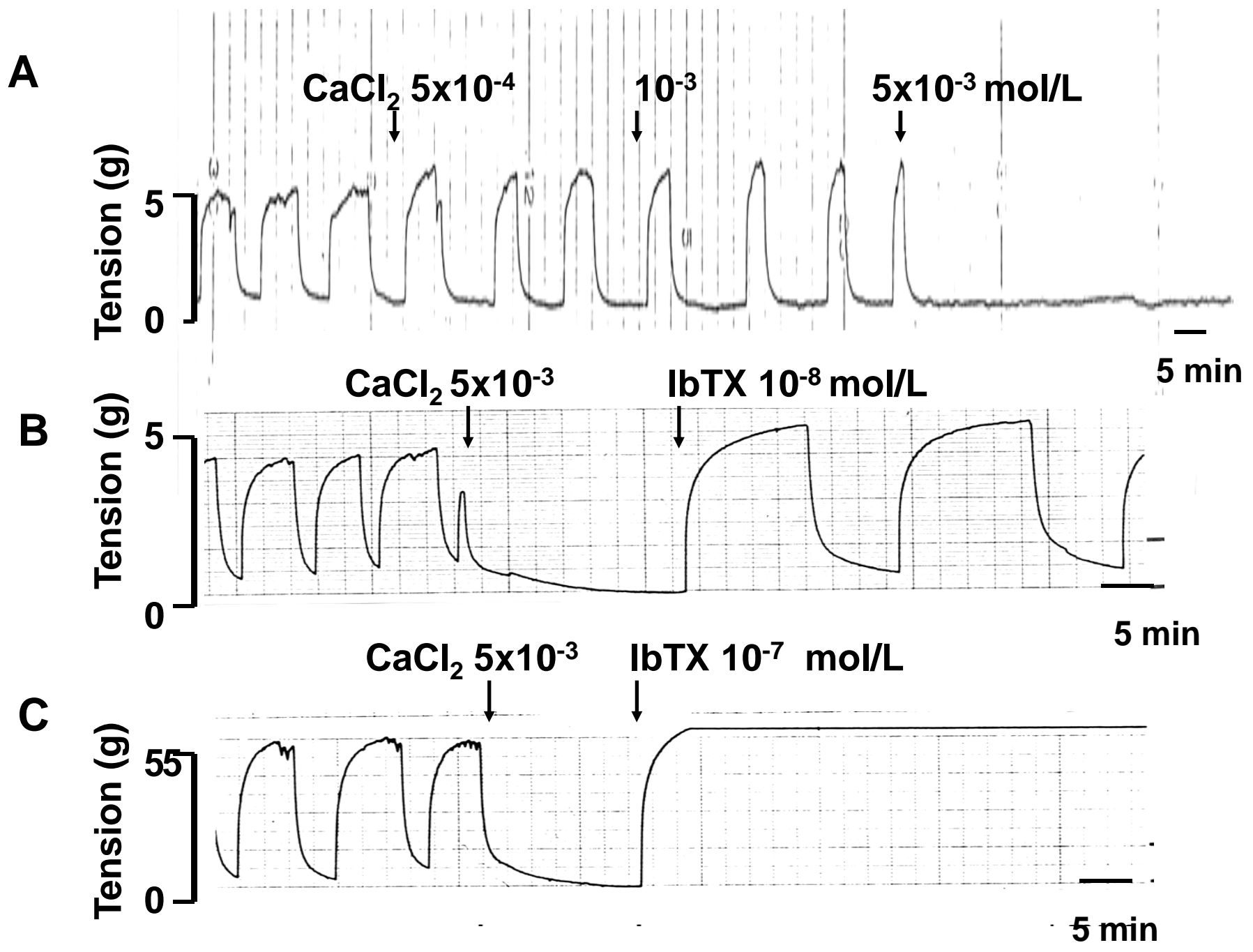

Fig. 4

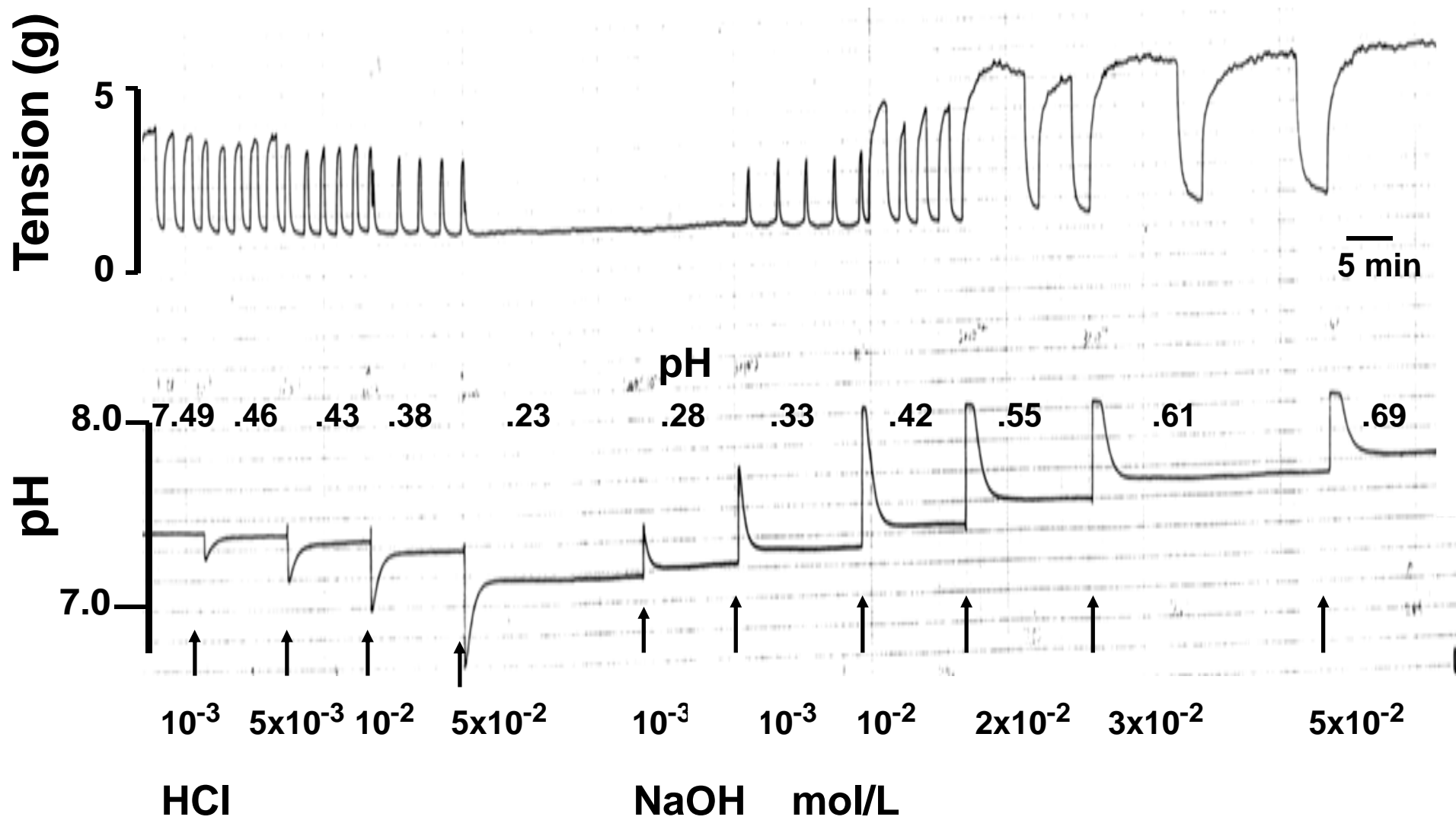

Fig. 5

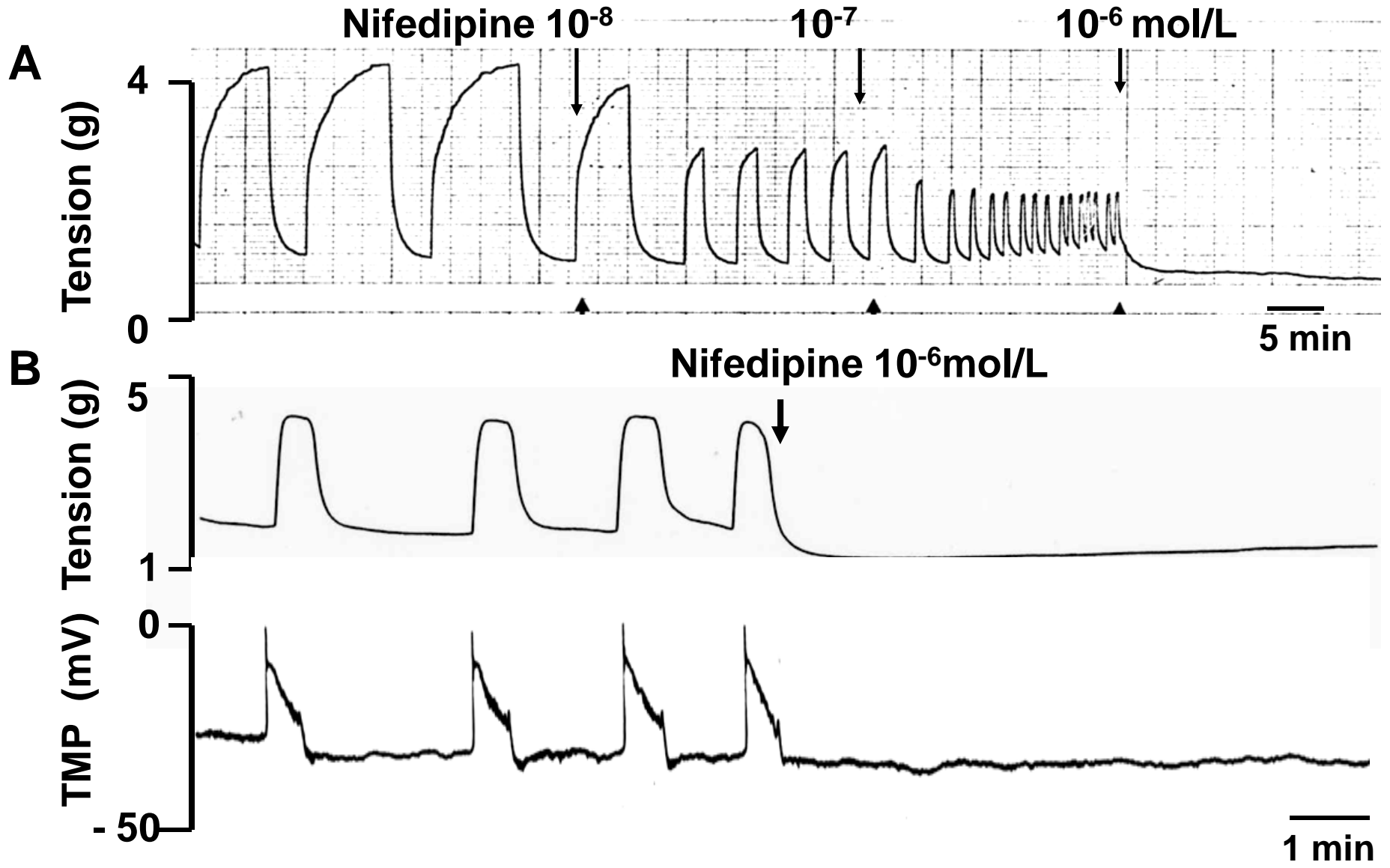

Fig.6

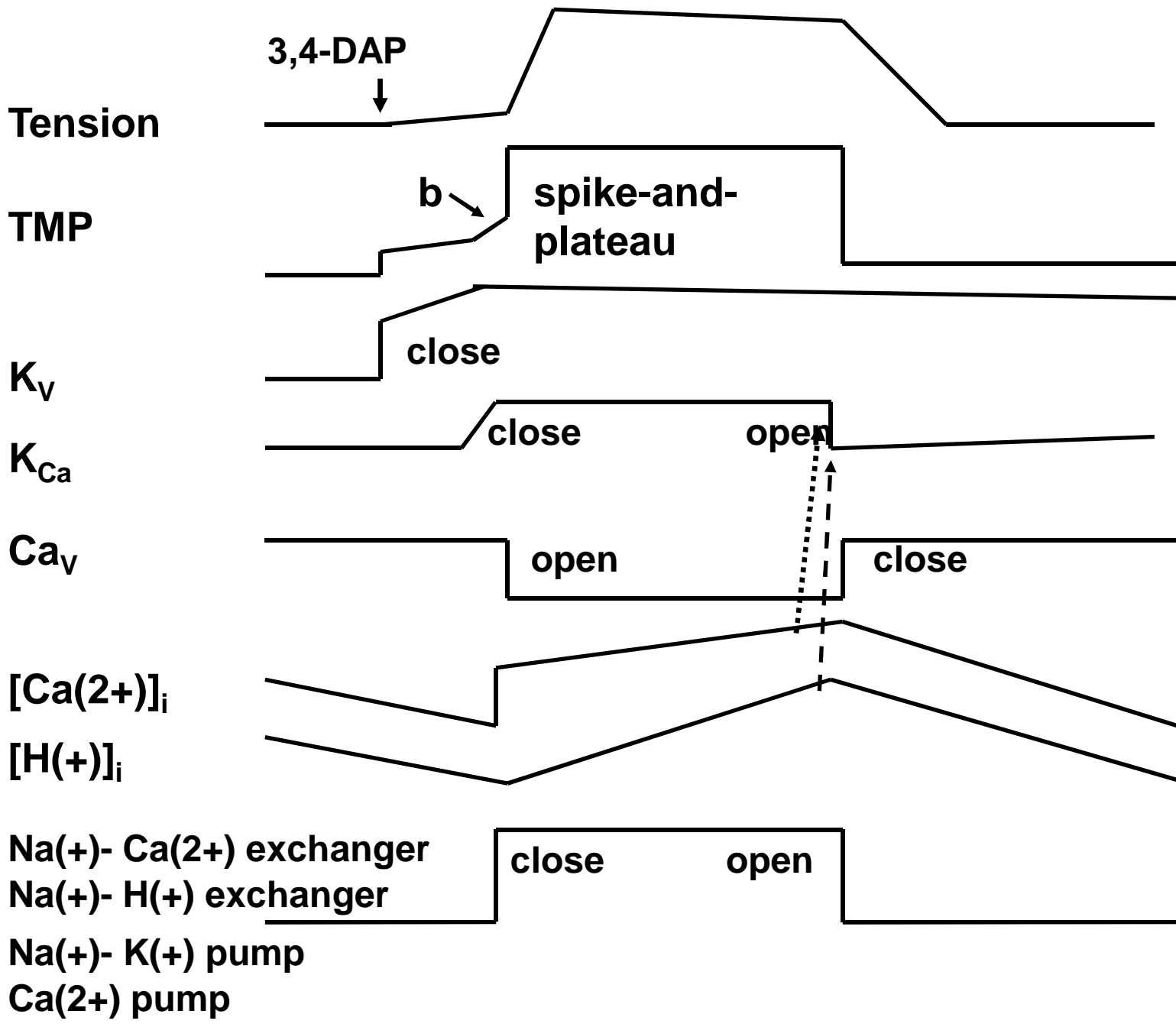
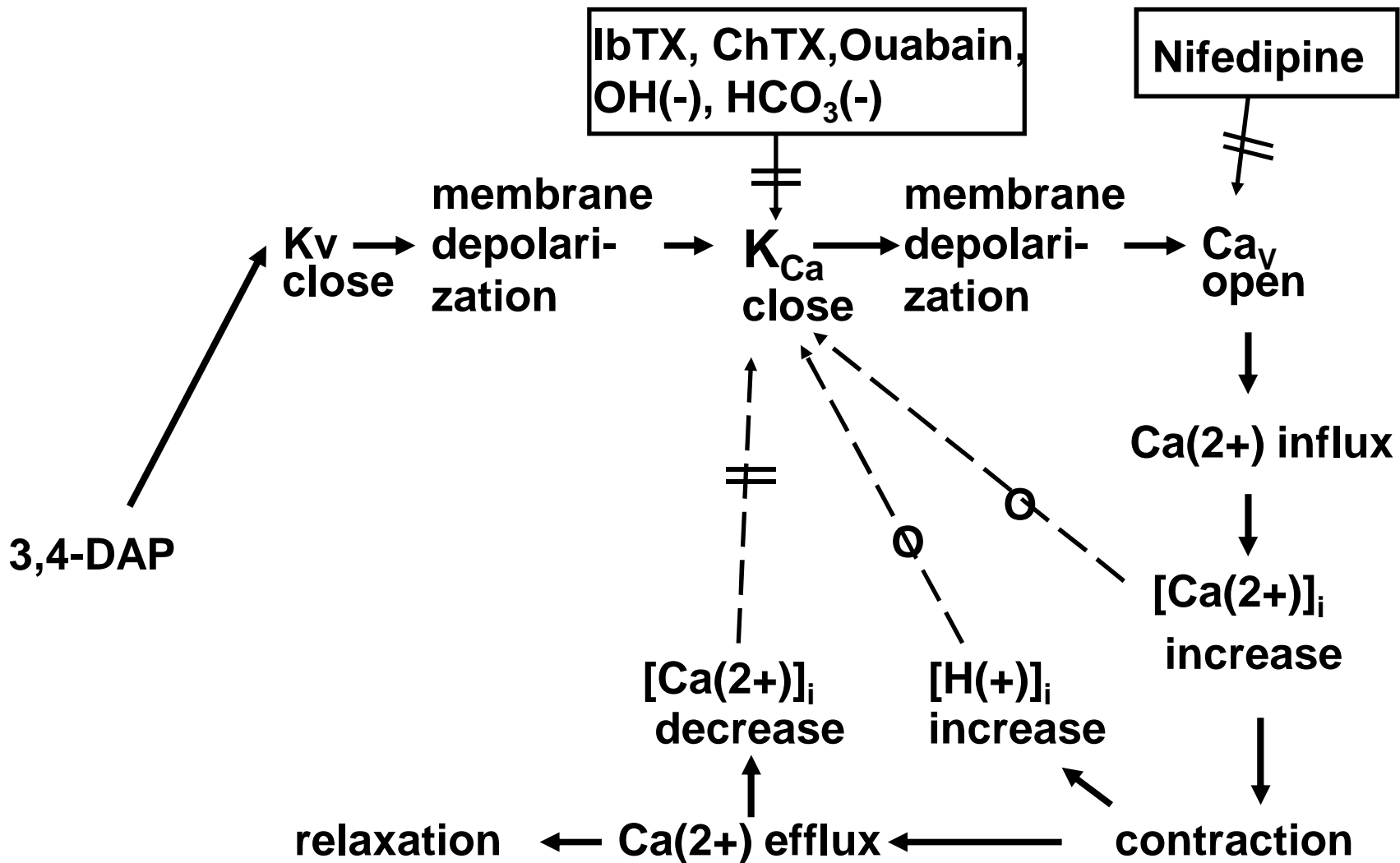

Fig. 7



→ direction of changes —||— close - - Θ - Θ open

Fig.8